

## MODEL CUB4L, CUB4L8 & CUB4L8W - MINIATURE ELECTRONIC COUNTERS



UL Recognized Component,  
 File # E179259

- LCD, POSITIVE REFLECTIVE OR NEGATIVE TRANSMISSIVE WITH YELLOW/GREEN OR RED LED BACKLIGHTING
- INTERNAL LITHIUM BATTERY PROVIDES UP TO 6 YEARS OF UNINTERRUPTED OPERATION
- NEMA 4X/IP65 SEALED FRONT BEZEL
- FRONT PANEL RESET, REMOTE RESET, OR BOTH
- COUNT SPEEDS UP TO 5 KHz (Model Dependent)
- COUNT INPUT FROM 10 to 300 VAC/DC (CUB4L8W)
- WIRE CONNECTION MADE VIA SCREW CLAMP TYPE TERMINALS

### DESCRIPTION

The CUB4 offers a large display in a miniature package. There are three CUB4 counters to choose from; the CUB4L (6-digit counter), CUB4L8 (8-digit counter), and the CUB4L8W (8-digit counter with voltage input). You also have a choice of three displays; reflective, red backlight or green backlight.

The backlight versions require power from an external 9–28 VDC supply. The optional power supply (MLPS1000) is designed to be attached directly to the rear of the CUB4 and is powered from an 85–250 VAC source. The power supply provides 12 VDC @ 400 mA to power the backlight and sensor, if required.

The CUB4 series has a lightweight, high impact plastic case with a clear viewing window. The sealed front panel with the silicone rubber reset button meets NEMA 4X/IP65 specifications for wash-down and/or dusty environments, when properly installed.

### SAFETY SUMMARY

All safety related regulations, local codes and instructions that appear in the manual or on equipment must be observed to ensure personal safety and to prevent damage to either the instrument or equipment connected to it. If equipment is used in a manner not specified by the manufacturer, the protection provided by the equipment may be impaired.

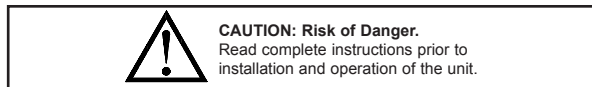

### ORDERING INFORMATION

MODEL NO.	DESCRIPTION	PART NUMBERS
CUB4L (6-digit)	Counter Positive Image Reflective	CUB4L000
	Counter w/Yel-Grn Backlighting	CUB4L010
	Counter w/Red Backlighting	CUB4L020
	Counter Positive Image Reflective w/V+ Terminal	CUB4LM00
CUB4L8 (8-digit)	Counter Positive Image Reflective	CUB4L800
	Counter w/Yel-Grn Backlighting	CUB4L810
	Counter w/Red Backlighting	CUB4L820
	Counter Positive Image Reflective w/V+ Terminal	CUB4L80M
CUB4L8W (8-digit w/VCM)	Counter Positive Image Reflective	CUB4L8W0
	Counter w/Yel-Grn Backlighting	CUB4L8W1
	Counter w/Red Backlighting	CUB4L8W2
	Counter Positive Image Reflective w/V+ Terminal	CUB4L8WM
MLPS	Micro Line/Sensor Power Supply	MLPS1000

For more information on Pricing, Enclosures & Panel Mount Kits refer to the RLC Catalog or contact your local RLC distributor.

### SPECIFICATIONS

- DISPLAY:**  
 CUB4L: 6-Digit, LCD, 0.48" (12.2 mm) high digits.  
 CUB4L8 & CUB4L8W: 8-Digit, LCD, 0.46" (11.7 mm) high digits.
- POWER SOURCE:** Internal 3.0 V lithium battery to provide up to 6 years of continuous operation. Battery life is dependent upon usage. Count and reset contacts that remain closed for long periods of time will reduce battery life.
- BACKLIGHT POWER REQUIREMENTS:** 9 to 28 VDC, 35 mA typical, 50 mA max. Above 26 VDC, derate operating temperature to 50°C. Must use the MLPS or a Class 2 or SELV rated power supply.
- INPUTS:**  
**All Inputs:**  $V_{IL}$  (low) = 0.5 V max.  
**Low Speed Input (CUB4L & CUB4L8):** 30 Hz from switch contact or open collector transistor with a 50% duty cycle.  
**Low Speed Input (CUB4L8W):** 10 to 300 VAC/DC, 50/60 Hz, 30 cps max.  $V_{IL}$  = 0.5 VDC max. Unit counts on positive going edge. Will not operate with Triac outputs.  
**High Speed Input (CUB4L):** 5 KHz from 4.0 V to 28.0 V bipolar output with a 50% duty cycle.  
**High Speed Input (CUB4L8):** 5 KHz at 2.0 V (3 V max) bipolar output with a 50% duty cycle.  
**Remote Reset:**  
 CUB4L: 15 msec min. pulse width (active low) from 4.0 V to 28.0 V bipolar output or an open collector transistor or a switch contact to common.

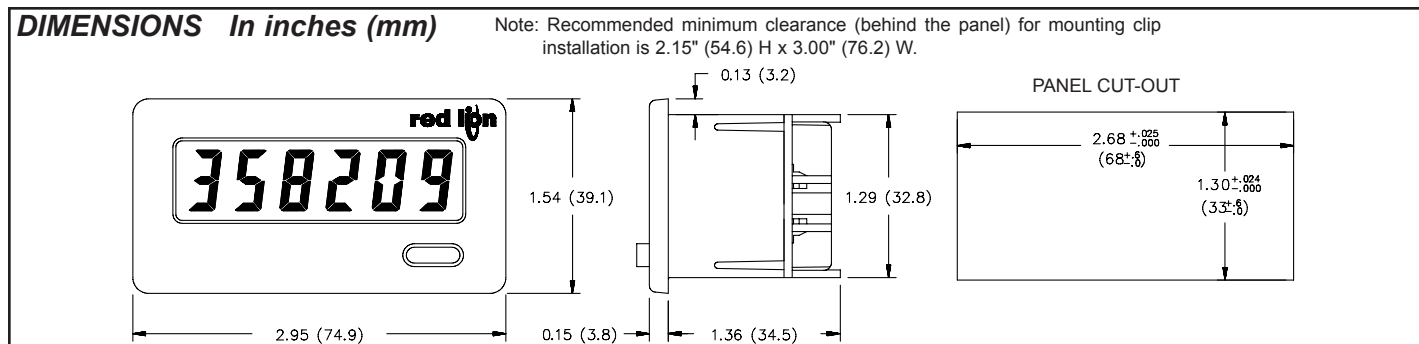

CUB4L8 & CUB4L8W: 15 msec min. pulse width (*active low*) from 3.0 V bipolar output or an open collector transistor or a switch contact to common.

**5. ENVIRONMENTAL CONDITIONS:**

**Operating Temperature:** 0 to 60°C (above 50°C, derate backlight operating voltage to 26 VDC max.).

**Storage Temperature:** -30 to 85°C

**Operating and Storage Humidity:** 85% max. (non-condensing) from 0°C to 50°C.

**Vibration According to IEC 68-2-6:** 5 to 500 Hz, in X, Y, Z direction for 1.5 hours, 5g's.

**Shock According to IEC 68-2-27:** Operational 30 g, 11 msec in 3 directions.

**Altitude:** Up to 2000 meters

**6. CERTIFICATIONS AND COMPLIANCES:**

**SAFETY**

UL Recognized Component, File # E179259, UL 61010-1, CSA C22.2 No. 61010-1

Recognized to U.S. and Canadian requirements under the Component Recognition Program of Underwriters Laboratories, Inc.

Type 4X Enclosure rating (Face only), UL50

IECEE CB Scheme Test Certificate # US/9257/UL,

CB Scheme Test Report # E179259-V01-S02

Issued by Underwriters Laboratories, Inc.

IEC 61010-1, EN 61010-1: Safety requirements for electrical equipment for measurement, control, and laboratory use, Part 1.

IP65 Enclosure rating (Face only), IEC 529

**ELECTROMAGNETIC COMPATIBILITY**

**Immunity to EN 50082-2**

Electrostatic discharge	EN 61000-4-2	Level 2; 4 Kv contact Level 3; 8 Kv air
Electromagnetic RF fields	EN 61000-4-3	Level 3; 10 V/m 80 MHz - 1 GHz
Fast transients (burst)	EN 61000-4-4	Level 4; 2 Kv I/O Level 3; 2 Kv power
RF conducted interference	EN 61000-4-6	Level 3; 10 V/rms 150 KHz - 80 MHz
Power frequency magnetic fields	EN 61000-4-8	Level 4; 30 A/m
Simulation of cordless telephone	ENV 50204	Level 3; 10 V/m 900 MHz ± 5 MHz 200 Hz, 50% duty cycle

**Emissions to EN 50081-2**

RF interference	EN 55011	Class B
-----------------	----------	---------

Refer to the EMC Installation Guidelines section of this bulletin for additional information.

**7. CONSTRUCTION:**

This unit is rated for NEMA 4X/IP65 indoor use. Installation Category I, Pollution Degree 2

**8. WEIGHT:** 3 oz. (85 grams)

**EMC INSTALLATION GUIDELINES**

Although Red Lion Controls Products are designed with a high degree of immunity to Electromagnetic Interference (EMI), proper installation and wiring methods must be followed to ensure compatibility in each application. The type of the electrical noise, source or coupling method into a unit may be different for various installations. Cable length, routing, and shield termination are very important and can mean the difference between a successful or troublesome installation. Listed are some EMI guidelines for a successful installation in an industrial environment.

- Use shielded (screened) cables for all Signal and Control inputs. The shield (screen) pigtail connection should be made as short as possible. The connection point for the shield depends somewhat upon the application. Listed below are the recommended methods of connecting the shield, in order of their effectiveness.
  - Connect the shield only at the panel where the unit is mounted to earth ground (protective earth).
  - Connect the shield to earth ground at both ends of the cable, usually when the noise source frequency is above 1 MHz.
  - Connect the shield to common of the unit and leave the other end of the shield unconnected and insulated from earth ground.
- Never run Signal or Control cables in the same conduit or raceway with AC power lines, conductors feeding motors, solenoids, SCR controls, and heaters, etc. The cables should be run in metal conduit that is properly grounded. This is especially useful in applications where cable runs are long and portable two-way radios are used in close proximity or if the installation is near a commercial radio transmitter.
- Signal or Control cables within an enclosure should be routed as far away as possible from contactors, control relays, transformers, and other noisy components.
- In extremely high EMI environments, the use of external EMI suppression devices, such as ferrite suppression cores, is effective. Install them on Signal and Control cables as close to the unit as possible. Loop the cable through the core several times or use multiple cores on each cable for additional protection. Install line filters on the power input cable to the unit to suppress power line interference. Install them near the power entry point of the enclosure. The following EMI suppression devices (or equivalent) are recommended:

**Ferrite Suppression Cores for signal and control cables:**

- Fair-Rite # 0443167251 (RLC #FCOR0000)
- TDK # ZCAT3035-1330A
- Steward #28B2029-0A0

**Line Filters for input power cables:**

- Schaffner # FN610-1/07 (RLC #LFIL0000)
- Schaffner # FN670-1.8/07
- Corcom #1VR3

*Note: Reference manufacturer's instructions when installing a line filter.*

- Long cable runs are more susceptible to EMI pickup than short cable runs. Therefore, keep cable runs as short as possible.

**INSTALLATION ENVIRONMENT**

The unit should be installed in a location that does not exceed the maximum operating temperature and provides good air circulation. Placing the unit near devices that generate excessive heat should be avoided.

The bezel should be cleaned only with a soft cloth and neutral soap product. Do NOT use solvents. Continuous exposure to direct sunlight may accelerate the aging process of the bezel.

Do not use tools of any kind (screwdrivers, pens, pencils, etc.) to operate the keypad of the unit.

**Installation**

The CUB4 series of products meet NEMA 4X/IP65 requirements for indoor use, when properly installed. The units are intended to be mounted into an enclosed panel. The viewing window and reset button are factory sealed for a washdown environment. A sponge rubber gasket and mounting clip are provided for sealing the unit in the panel cut-out.

The following procedure assures proper installation:

- Cut panel opening to specified dimensions. Remove burrs and clean around panel opening.
- Carefully remove the center section of the panel gasket and discard. Slide gasket over rear of the unit to the back of the bezel.
- Assemble nut fastener first and then mounting screw onto both sides of mounting clip. Tip of screw should not project from hole in mounting clip.
- Install CUB4 unit through the panel cut-out until front bezel flange contacts the panel-mounted gasket.
- Slide the mounting clip over the rear of the unit until the mounting clip is against the back of the panel. The mounting clip has latching features which engage into mating features on the CUB4 housing.

*Note: It is necessary to hold the unit in place when sliding mounting clip into position.*

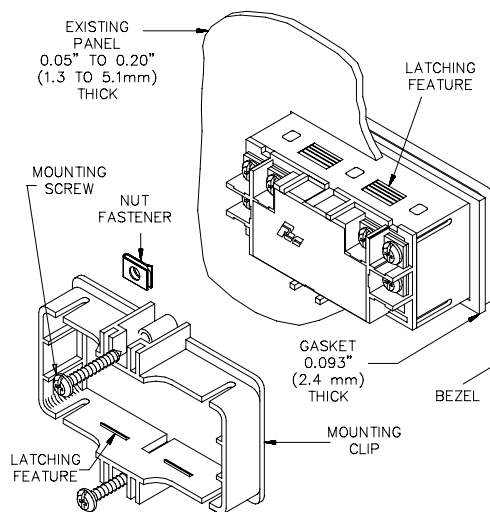

- Alternately tighten each screw to ensure uniform gasket pressure. Visually inspect the front panel gasket. The gasket should be compressed about 75 to 80% of its original thickness. (Recommended torque is 28 to 36 in-oz.) If not, gradually turn mounting screws to further compress gasket.
- If gasket is not adequately compressed, and mounting screws can no longer be turned, loosen mounting screws and check that mounting clip is latched as close as possible to panel. Repeat procedure for tightening mounting screws.

## WIRING CONNECTIONS

The electrical connections are made via rear screw-clamp terminals located on the back of the unit. When wiring the unit, use the label to identify the wire position with the proper function. All conductors should meet voltage and current ratings for each terminal. Also cabling should conform to appropriate standards of good installation, local codes and regulations. It is recommended that power supplied to the unit (AC or DC) be protected by a fuse or circuit breaker. Strip the wire, leaving approximately 1/4" bare wire exposed (*stranded wires should be tinned with solder*). Insert the wire into the screw-clamp terminal and tighten down the screw until the wire is clamped tightly. Each terminal can accept up to two #14 AWG wires.

*Note: The Reflective CUB4 will NOT have a screw terminal installed at the V+ terminal, since it is NOT required for operation and is not internally connected. Refer to the Ordering Information for the part number of a reflective model that will accommodate the MLPS.*

## Backlight Wiring

Optional backlight versions of the CUB4 require an external 9-28 VDC power supply. The external supply is connected between the V+ and Common terminals.

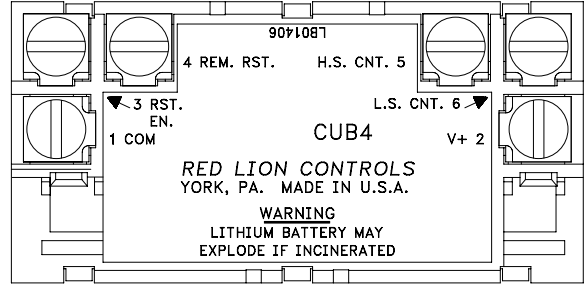

**Warning:** Lithium battery may explode if incinerated.

**Caution:** All leads will be at the same line potential as the input leads.

### CUB4L AND CUB4L8 LOW SPEED COUNT INPUT, 30 Hz MAX.

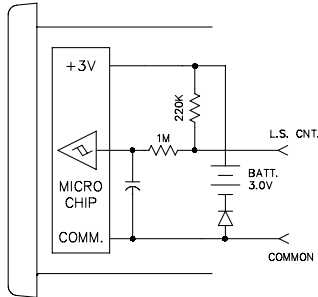

Pulling the "L.S. CNT." Input to Common with a mechanical or solid-state switch increments the counter. The low pass filter used with a Schmidt trigger circuit debounces mechanical switch signals. The switch load is 14  $\mu$ A (max. voltage drop 0.5 V) when ON. The OFF-state leakage current must be less than 2  $\mu$ A. Motor starter contacts, tungsten contacts, and brush-type contacts should NOT be used.

SWITCH CONTACT INPUT

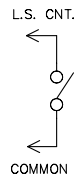

NPN O.C. TRANSISTOR OR (N) FET INPUT

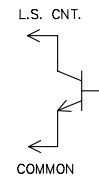

PNP O.C. TRANSISTOR OR (P) FET INPUT

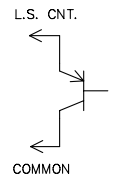

### CUB4L8W L.S. INPUT, 30 CPS MAX.

The CUB4L8W accepts most machine control voltage signals. The input accepts AC (50/60 Hz) or DC control voltages from 10 to 300 V at count speeds up to 30 cps. The unit counts on the positive going edge of the input signal.



**WARNING:** Any lead may be at hazardous live input potential. External wiring and devices connected to the unit must be rated the same as applied signal input voltage and be properly isolated from Class 2 or SELV circuitry.

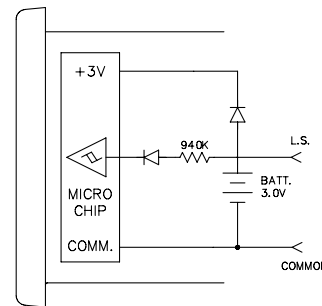

### CUB4L HIGH SPEED COUNT INPUT, 5 KHz MAX.

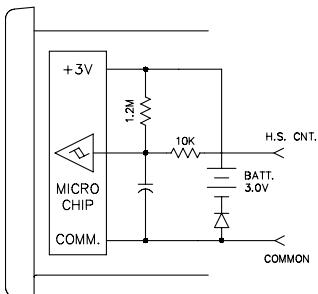

The "H.S. CNT." Input allows the CUB Counter to operate at speeds up to 5 KHz when driven by bi-polar outputs. Input drive voltage must be limited to 28.0 V maximum to avoid damage to the counter.

**INPUT PULSE EXCURSION LIMITS**  
 $V_{IH}$  (High) = +4.0 V min., +28.0 V max.  
 $V_{IL}$  (Low) = +0.5 V max.

TTL OR CMOS OUTPUT

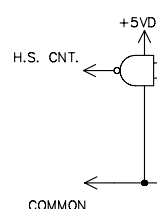

NPN O.C. TRANSISTOR OUTPUT

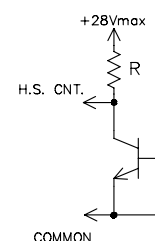

PNP O.C. TRANSISTOR OR BI-POLAR OUTPUT

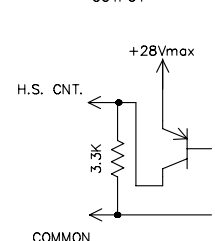

## CUB4L8 HIGH SPEED COUNT INPUT, 5 Hz MAX.

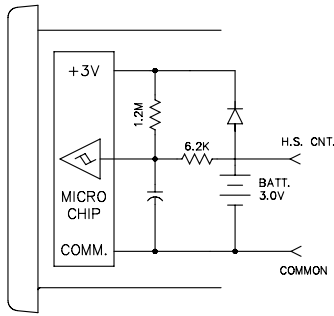

The "H.S. CNT." Input allows the CUB Counter to operate at speeds up to 5 KHz when driven by bi-polar outputs or external circuits having an output impedance of 3.3 K $\Omega$  or less. Input drive voltage must be limited to 3 V maximum to avoid damage to the counter. CMOS and TTL logic outputs can be loaded with a resistor (R<sub>I</sub>) to limit drive voltage, or a voltage divider can be used as shown for the PNP O.C. transistor output.

TTL OR CMOS OUTPUT

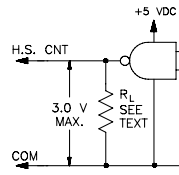

FIG 1

PNP O.C. TRANSISTOR OR BI-POLAR OUTPUT

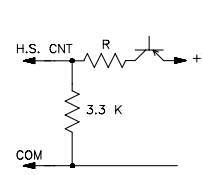

FIG 2

NPN O.C. TRANSISTOR

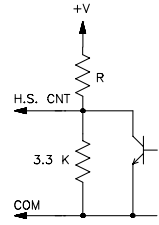

FIG 3

### INPUT PULSE EXCURSION LIMITS

$V_{IN}$  (High) = 2.0 V min., 3.0 V max.  
 $V_{IL}$  (Low) =  $\pm 0.5$  V max.

R values for Fig 2 & 3	
+V	R
+5 V	2.2 K
+12 V	10 K
+18 V	16 K
+24 V	24 K

## RESET OPTIONS

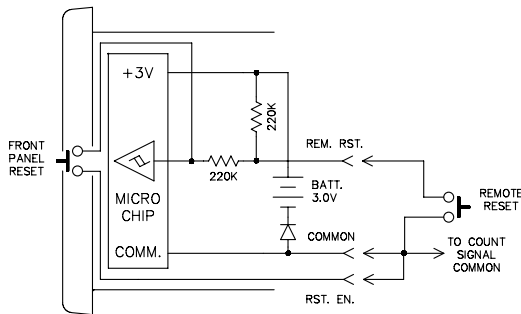

Connecting a wire from the "RST. EN." (Reset Enable) Input terminal to Common will enable the front panel Reset button. When Remote Reset is required, a wire is connected from the "REM. RST." input terminal to Common. Pulling this input low causes the counter to reset. The "REM. RST." can be pulled low by either a mechanical switch or solid-state transistor switch. Switch load and leakage are the same as for "L.S. CNT." Input above.

*Note: The RC protection circuit on the "REM. RST." Input causes a delay of approximately 15 msec in Reset response.*

## BACKLIGHT OPTION

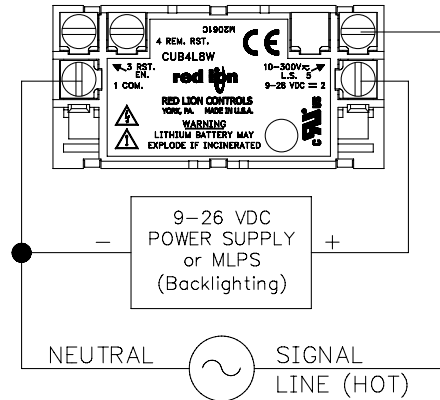

Optional backlight versions of the CUB4 require an external 9-28 VDC power supply. The external supply is connected between the +V and Common terminals as shown in the drawing.

Red Lion Controls optional power supply (MLPS1000) is designed to be attached directly to the rear of a CUB4 and is powered from a 85 to 250 VAC source. The MLPS provides power for unit backlighting and a sensor.



**WARNING:** When connecting the wiring for a backlit CUB4L8W measuring an AC input voltage, the neutral of the single phase AC signal is connected to Terminal 1 (COM), and line (hot) is connected to Terminal 5 (LS). The DC supply for the backlighting is connected as shown in the drawing. Three phase AC applications require an isolation transformer.

## TROUBLESHOOTING

For further technical assistance, contact technical support at the appropriate company numbers listed.

Red Lion Controls  
 20 Willow Springs Circle  
 York PA 17406  
 Tel +1 (717) 767-6511  
 Fax +1 (717) 764-0839

Red Lion Controls BV  
 Printerweg 10  
 NL - 3821 AD Amersfoort  
 Tel +31 (0) 334 723 225  
 Fax +31 (0) 334 893 793

Red Lion Controls AP  
 31, Kaki Bukit Road 3,  
 #06-04/05 TechLink  
 Singapore 417818  
 Tel +65 6744-6613  
 Fax +65 6743-3360